

# INTERNET FULFILLMENT

SEMI-AUTOMATIC & FULLY-AUTOMATIC RANDOM SOLUTIONS

*U.S. e-commerce statistics report that the internet fulfillment market continues to grow at an annual double digit rate.*



**CSX**  
Fully Automatic Random Sealer

TO MEET THIS GROWTH,  
**BESTPACK** HAS CREATED SOLUTIONS TO:



MINIMIZE "DIM-WEIGHT" CHARGES  
AND MEET **RANDOM**  
CAPABILITY REQUIREMENTS



MEET SPEED &  
EFFICIENCY  
REQUIREMENT METRICS

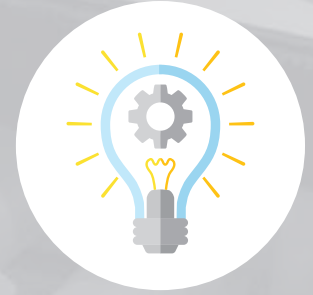

PROVIDE  
CUSTOMIZED  
APPLICATION SOLUTIONS

## RECOMMENDED SOLUTIONS



**RS20**  
Random Bottom  
Only Sealer



**RSBFT**  
Random Bottom  
Sidedrive w/ T-Rail

# CHECK OUT OUR SEMI-AUTOMATIC & FULLY-AUTOMATIC SOLUTION TO INTERNET FULFILLMENT PACKAGING

## BestPack SEMI-AUTOMATIC SOLUTION

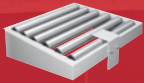

**CM500-570A48**

Short Infeed/Exit Conveyor  
19.75" x 22.5"

or

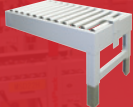

**CM1000-570A48**

Long Infeed/Exit Conveyor  
39.50" x 22.5"



**RS22**  
Random  
Sidedrive

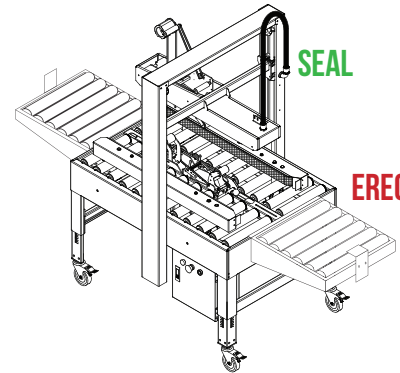

## BestPack SEMI-AUTOMATIC SOLUTION



**RS20**

Random Bottom  
Only Sealer

or



**RSBFT**

Random Bottom  
Sidedrive w/ T-Rail



**RS22**  
Random  
Sidedrive

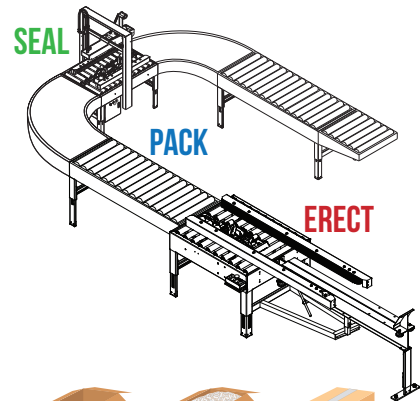

## SEMI-AUTOMATIC SOLUTION



**RS20**

Random Bottom  
Only Sealer

or



**RSBFT**

Random Bottom  
Sidedrive w/ T-Rail



## FULLY-AUTOMATIC SOLUTION



**CSX**  
Fully Automatic  
Random Sealer

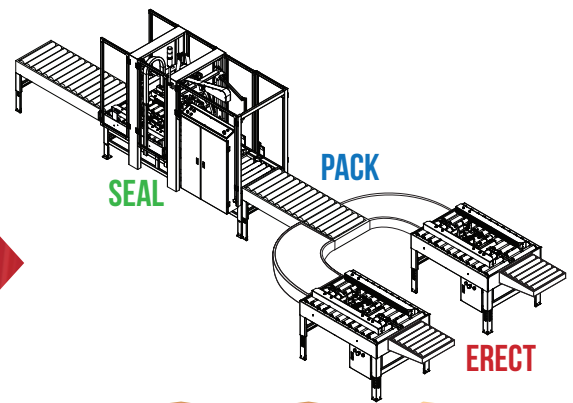

Whatever you need to successfully support Internet Fulfillment, your friendly and knowledgeable engineering and customer service team members at **(888) 588-2378** will provide the **BestPack Advantage**.