

LIGHT TO HEAVY DUTY

HOT MELT CARTON SEALING TAPE



INSTANT ADHESION
TO CARTONS

QUICK HIGHLIGHTS

- Great Initial Tack
- Consistent & Easy Release
- Specially Formulated 110% Elongation Low Stretch Cast Film (Increasing Machine Length Roll Performance)
- RoHS Compliant
- Meets FDA Food Requirements for Indirect Food Contact



1.6 MIL (40 MICRON)* Total Thickness	30 oz/inch WIDTH*** Peel Adhesion	0.6 MIL (15 MICRON)* Adhesive Thickness
1.0 MIL (25 MICRON)* Film Thickness	19 LBS/IN WIDTH** Tensile Strength	110%** Elongation % At Break
Test Methods: * ASTM D-3652; ** ASTM D-3759; *** ASTM D-3330		

SERVICE TEMPERATURE
Minimum Temp.: 30°F Maximum Temp.: 140°F

USAGE & STORAGE TEMPERATURE
Minimum Temp.: 32°F Maximum Temp.: 104°F

IDEAL STORAGE TEMPERATURE
Ideal Storage Temp.: 77°F +/- 5°F Ideal Storage Humidity: 55% +/- 5%

AVAILABLE COLORS: CLEAR

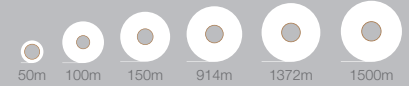
AVAILABLE LENGTHS: 

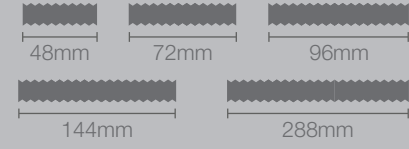
AVAILABLE WIDTHS: 

HT16

1.6 MIL (40 MICRON) TOTAL TAPE THICKNESS
25 MICRON CAST BOPP LOW ELONGATION FILM
HOT MELT ADHESIVE

HT16 is an economy grade carton sealing tape, perfect for light-duty sealing.



LEARN MORE ABOUT OUR TAPE:
 BROCHURES | MATERIAL SAFETY DATA SHEET | ROHS INFORMATION