

## CSEEG Series

### Fully Automatic Random Side Drive

The BestPack CSEEG Series is a Fully Automatic Random Carton Sealer. Designed for flexibility and high speed, our advanced engineering allows the CSEEG to seal cartons and crate pass through at 20 - 30 cartons per minute. Our CSEEG machine is purpose built for the egg industry's standard carton sizes: 30, 24, 18, 15, 12, 9, and 5 dozen, as well as for reusable plastic crates.

Our CSEEG line incorporates our exclusive 2" or 3" pop-out pressure-sensitive "High Speed" tape heads with BestPack's patented tab adjustment. All BestPack units are available in our standard baked enamel finish and food-grade 304 stainless steel for 21 CFR 110 compliance.



## Key Points of the Carton Sealer



**No Operator  
Required**



**Random Cartons**



**Top & Bottom Seal**

## Features

- In-line Carton Closure
- Operator Free Design
- Handles Multiple Length & Height Carton Sizes at the Same Time
- Independent 3-stage Operation: Indexing, Flap Folding, & Sealing
- Allen-Bradley PLC Logic w/ Ethernet Capabilities
- Indexer with Carton Centering Device
- Plastic Crate Pass-Through
- High Speed Motors for Belt Speed of 125 ft. per min.
- Reduced Cycle Time
- Carton Height Sensors
- Tape Roll Lengths: 1,000 yd. & 1,500 yd.
- Heavy Duty Frame
- UL Approved Electrical Parts

- Adjustable Bed Height from 22.0" to 30.0"
- Interlock Safety Gates
- Capable of Interchanging 2", 3", 4", & 6" Tape Heads
- Low Tape/No Tape on Carton/No Cut Sensors & Alarm
- Casters
- Operation Manual with Tools

## Options

- Food Grade 304 Stainless Steel
- Lower Stainless Steel Legs

# Extra Accessories to Improve Efficiency



\*Spare Parts Kit May Vary\*

Spare Parts Kit



Infeed/Exit Conveyor  
w/ L-Bracket Holder/Stopper



Spare Tape Head



Carton Sealing Tape

- Long Infeed/Exit Conveyor w/ L-Bracket Stabilizer

## Machine & Carton Specifications

**110 Volts 60 Hz**  
20 AMP  
Power Requirements

**Up to 30 Cartons/min.**  
Speed

**85 PSI**  
12+ SCFM  
Air Requirements

**1,320 lbs**  
Shipping Weight

Model	Machine Dimensions Length x Width x Height	Carton Range* Length (min. - max.) x Width (min. - max.) x Height (min. - max.)	Conveyor Height Adjustment Height (min. - max.)	Cartons per min.	Shipping Weight (lbs.)
CSE11-2H** <b>2" Tape Head</b>	(100.0") x (38.5") x (88.0")	(6.0" - 25.5") x (6.0" - 14.0") x (6.5" - 20.0")	(22.5" - 30.0")	Up to 30	1320
CSE11-3H** <b>3" Tape Head</b>	(100.0") x (38.5") x (88.0")	(6.0" - 25.5") x (6.0" - 14.0") x (6.5" - 20.0")	(22.5" - 30.0")	Up to 30	1320

Information subject to change without notice.

\*Outside Dimensions Only  
\*\*High Speed

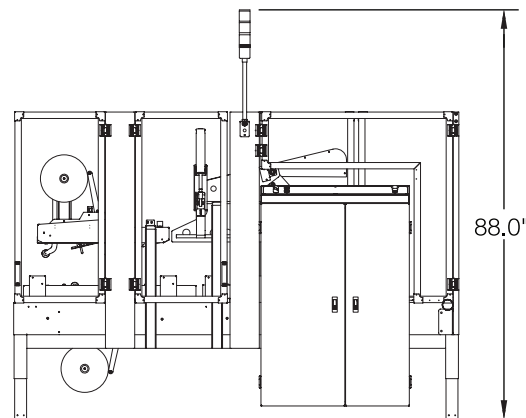
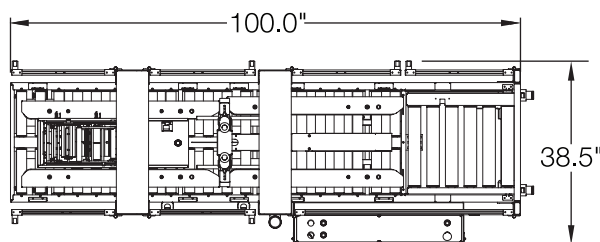

Note: Dimensions are all subject to change without prior notification. Call BestPack for pricing.