

MSD22-6 FOOTPRINT

MANUAL SIDEDRIVE DUAL MAST CARTON SEALER

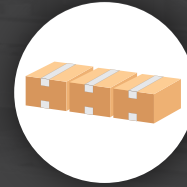

OPERATOR REQUIRED



UNIFORM CARTONS



TOP & BOTTOM SEAL

MACHINE MEASUREMENTS

39.5" X 32.8" X 70.3"
LENGTH WIDTH HEIGHT

TOP VIEW

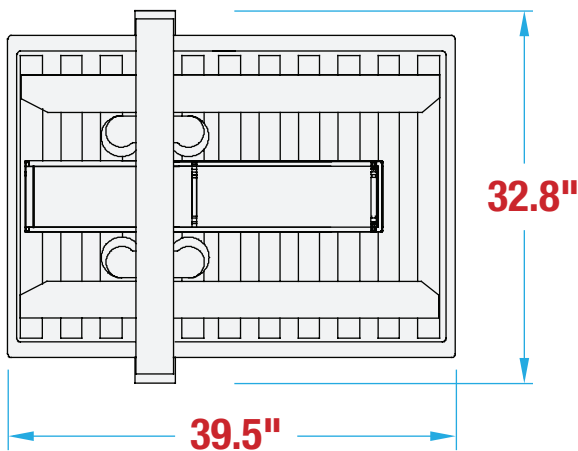

SIDE VIEW

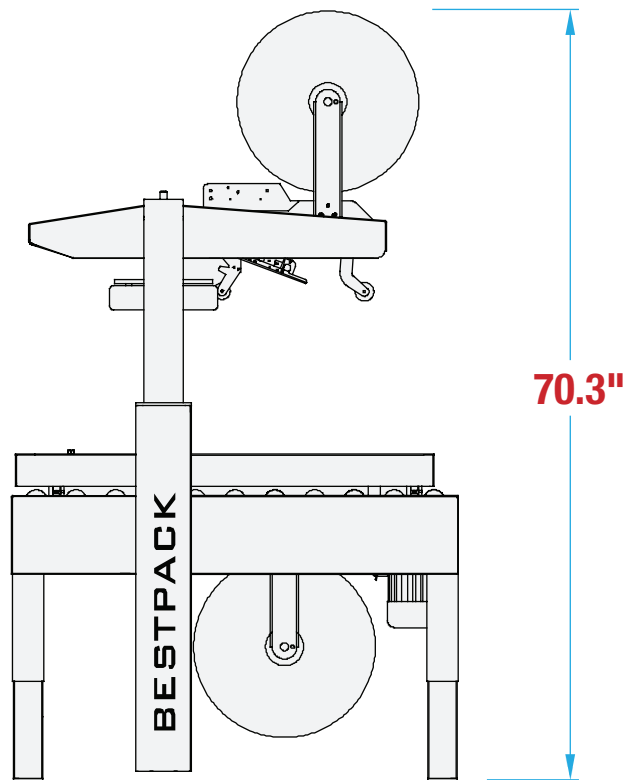

Note: Dimensions are all subject to change without prior notification. Call BestPack for pricing.