



UNIVERSAL TAPE HEAD ADAPTER FORM

Name of Contact

Phone Number

Email Address

Company

PLEASE SELECT ONE:

Distributor

End-User

Which Machine are you planning to insert the NC Tape Head?

SERIAL NUMBER:

If your machine is not listed below, please provide the machine make and model.

MAKE:

MODEL:

3M-MATIC

- 700a-s
- 800ab3
- a80-3
- 7000a Pro
- 800asb
- 800ab
- a20-s
- a80b-3
- 7000a3 pro
- 200a
- a80
- 200a3
- 8000a3
- a80b
- a20
- 7000r3 Pro
- 800r3
- 800r
- 7000r Pro
- 800rks
- 7000r

Other

IPG

- AUTO H20
- USA 2021-BFF
- USA 2024-SB
- USA 2024-SB-SS
- USA 2024-SB TTH
- USA 20-B
- USA 20-BFF
- USA 2324-BB
- USA 2324-OPF
- USA 2324-TB
- USA 3036-SB
- USC 2020-SB
- USC 2020-SB SS
- USC 2020-TB
- RSA 2024-SB
- RSA 2024-TB
- RSA 2024-WAT
- RSA 20-B
- RSA 3036-SB
- UA 262024-SB
- CE-10P WAT
- CE12-P

Other

LANTECH

- CS-1000
- CS-300
- CS-Random
- CS Random HS
- CI-1000
- C-2000
- C-1000
- C-400
- C-300
- ProfitPack 2
- ProfitPack 1

Other

WEXXAR BEL

- BEL 505
- BEL 505G3
- BEL 290
- BEL 252
- BEL 150
- BEL 180
- BEL 185
- BEL 250

Other

LOVESHAW

- LD-X
- LD-Xss
- LD-7
- Uniform Legend
- LDX-UTB
- LD-3SB
- SP-304
- LD-19SB
- LD-16A
- LD-24
- LDX-RTB 3.0
- Random Legend
- LDX-RTB A
- LD-16AE
- LD-16AR

Other

TAPE HEAD SIZE:

 2" 3"

TAPE HEAD ORIENTATION:

 Top Bottom

(For Side Sealers)

 Left Right

LOW-TAPE SENSOR:

 Yes No

NO-TAPE SENSOR:

 Yes No

RECORD TAPE HEAD & MACHINE DIMENSIONS

The following questions require you to take measurements of the current tape head and machine.

 [CLICK HERE FOR VIDEO: HOW TO MEASURE THE TAPE HEAD](#)

MEASURING UNIT: inch cm mm

HOW IS THE TAPEHEAD MOUNTED ON YOUR MACHINE?

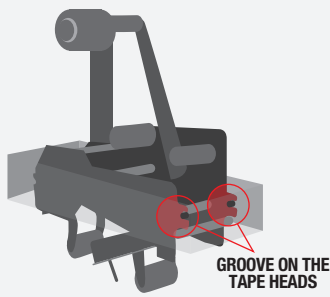

GROOVE
If it's hooked into the shaft please answer C, H, & I.

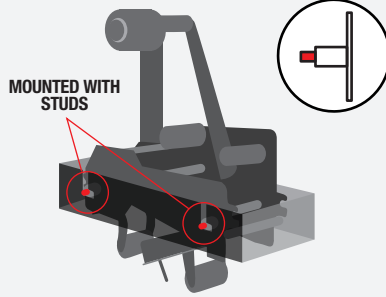

STUDS
If it's sitting on the slot please answer A through I.
Slot varies based on machine.

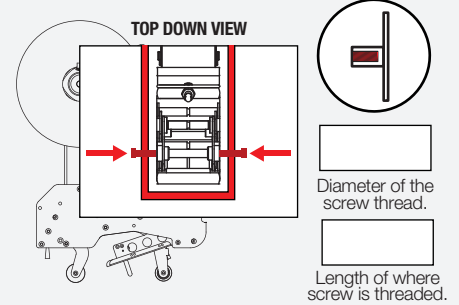

SCREWS
If it's mounted from the outside please answer A, B, C, D, H & I

Please also **attach photos** of your current tape head, and how it is mounted on the machine with tape measure references.)

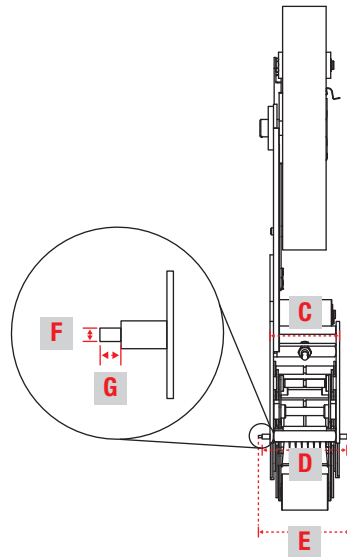
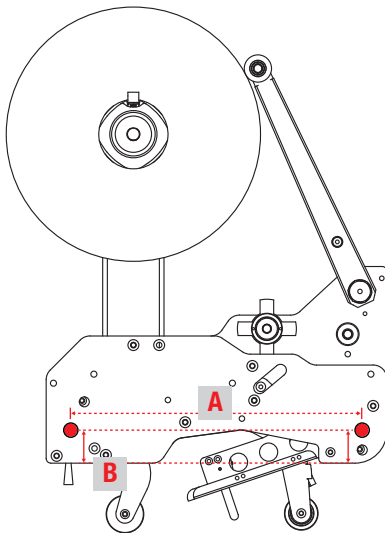

- A. The length between the two centers of the studs.
- B. The height from the bottom of the tape head to the center of the studs.
- C. The width of the current tape head.
- D. The width of the two shoulders of the studs.
- E. The width of the two ends of the studs.
- F. The diameter of the end of the stud.
- G. The width of the end of the stud.
- H. The width of the tape head cavity on your current machine.
- I. The length of the tape head cavity on your current machine.

- A.
- B.
- C.
- D.
- E.
- F.
- G.
- H.
- I.

NOTE: MEASURE WITH PRECISION UP TO 1/16" OR 2mm.

NOTE: MEASURE WITH PRECISION UP TO 1/16" OR 2mm.



For more information please go to:
WWW.BESTPACK.COM or call us at **1.888.588.2378**